



HB COFFEE ROASTER

HB-L2S

Manual

I.Important information

Any problem, please contact the manufacturer or your local dealer.

Safety

Machine only for roasting dust content of less than 1%, the minimum size of 5mm cleaned coffee beans.

The maximum number of processing each of 200g. Do not operate the machine in explosive areas.

Strictly in accordance with the provisions of the use of machinery.

The contaminated green coffee beans may still be hazardous to health after roasting.

Coffee beans should be stored dry. Moldy coffee beans can not be used.

When the machine is used under severe conditions, the possibility of security and functionality impaired.

Pay attention to the maintenance and repair of the machine.

If the device is not working properly, shall cease immediately to be checked.

Troubleshoot immediately.

Do not modify or rebuild equipment at will.

Qualification:

Since the device has a high risk of people not familiar with the equipment at risk can not be detected, do not operate.

Operators shall ensure that they are working in a safe and dangerous manner and comply with the Code of Practice

Staff Mechanical Engineer mechanical device, must be completed in technical training courses

Staff electrical engineer electrical devices must be completed in technical training courses

Personal protection

Hot machine parts may cause burns while the machine is in operation Handling hot parts of the machine should be equipped with protective equipment, such as gloves, protective clothing, etc.

Fire prevention

Excessive material temperature or combustible materials may cause a fire during operation

Ensure that staff have taken the necessary fire protection measures Ready to fire water interface

Place a fire extinguisher near the machine Explicit fire protection measures

II. Roasting machine parameters

Use environment

Name	Value
Operating temp	0-40 °C
Relative humidity	< 95 %

Roasting machine data

Machine size	115.0×50.0×89.5 cm
Total machine weight	125 kg
Dimensions of Silver Collector	32.0×32.0×113.0 cm
Weight of Silver Collector	37 kg
Liquefied gas consumption	0-0.3 m ³ / h
Natural gas consumption	0-0.6 m ³ / h
Hot air fan exhaust	5.08 m ³ /min
Cooling fan exhaust	9.5 m ³ /min
Exhaust air temperature	≤ 200 °C
Emissions of dust	< 50 mg/ m ³
Diameter of hot air exhaust pipe	56 mm
Cooling exhaust pipe diameter	76 mm

Electrical data

Total power of roasting machine	130 W
Drum power	90 W
Drum speed	20-64 rpm
Exhaust fan power	15 W
Cooling stirring speed	20 rpm
Exhaust fan power	120 W
Cooling fan power	240 W

III. Overview

Working Principle

Roasted coffee beans roasted in the bucket, then cooled cooling plate

Start roasting machine, roasting machine roasting barrel operation,
hot air fan operation

Open fire button, the machine warm-up

In the warm-up phase heater was heated roasting drum, the other side of the heated air is then introduced into a hot air oven baked in the barrel.

After the preheating temperature is reached, the coffee beans enter the roasting drum from the hopper. Roasting bucket and hot air will heat coffee beans simultaneously until it reaches the end of the roasting temperature.

When approaching the end of the roasting temperature, the start of the cooling coil, the cooling fan and the stirrer started. Coffee beans will be manually poured the cooling pan. Stirred with a stirrer and cooled using a cooling fan. Cooling at the end, open the beans door, pour coffee beans and close the cooling tray.

The roasting stage and the cooling stage can be carried out simultaneously.

COFFEE ROASTER Parts Graph

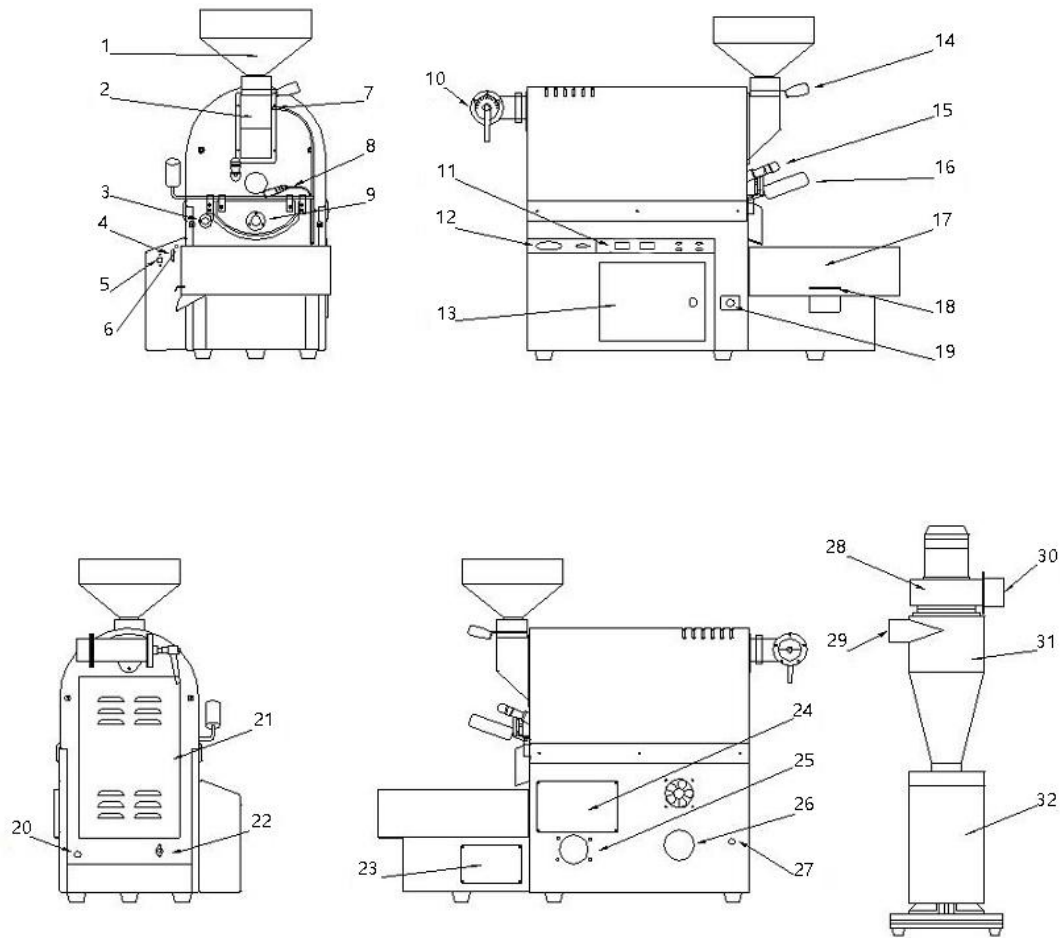

1. Filler
2. Bean inner
3. Fire window
4. WIFI antenna
5. USB
6. Screen switch button
7. Exhaust Temp.
8. Bean Temp.
9. Bean door
10. Air volume adjustment
11. Operation panel
12. Gas pressure gauge
13. Electrical Cabinet
14. Bean baffle
15. Sampling bar
16. Bean handle

17. Cooling plate
18. Bean door
19. Bean drawer
20. Power cord
21. Access panel
22. Gas inlet valve
23. Cool shredded bean bin
24. Fire platoon positions
25. Electronic air volume
26. Cooling air exhaust
27. Power socket for hot air fan
28. Hot air fan
29. Silver barrel air inlet
30. Hot air exhaust
31. Silver skin bucket
32. Silver trash can

switch panel



Top-down indicator are: Power indicator light, USB lights, WIFI indicator

Display:

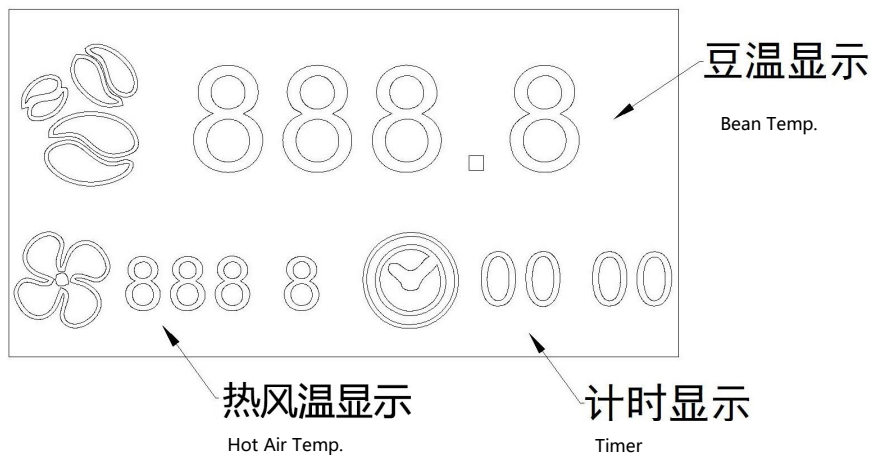

HB coffee roaster to provide four temperature display:

1. Exhaust Temp.
2. Hot Air Temp.
3. Bean Temp.
4. Inside-Drum Temp.

When the roasting machine connected to the computer through the roasting curve recording software arbitrary choice of two temperatures as a display. Timing function can be achieved through the timing button below the display.

Press once to start the timer, then press again to stop timing. Press 4 seconds timer to reset.

IV. Installation and Adjustment

Installation space

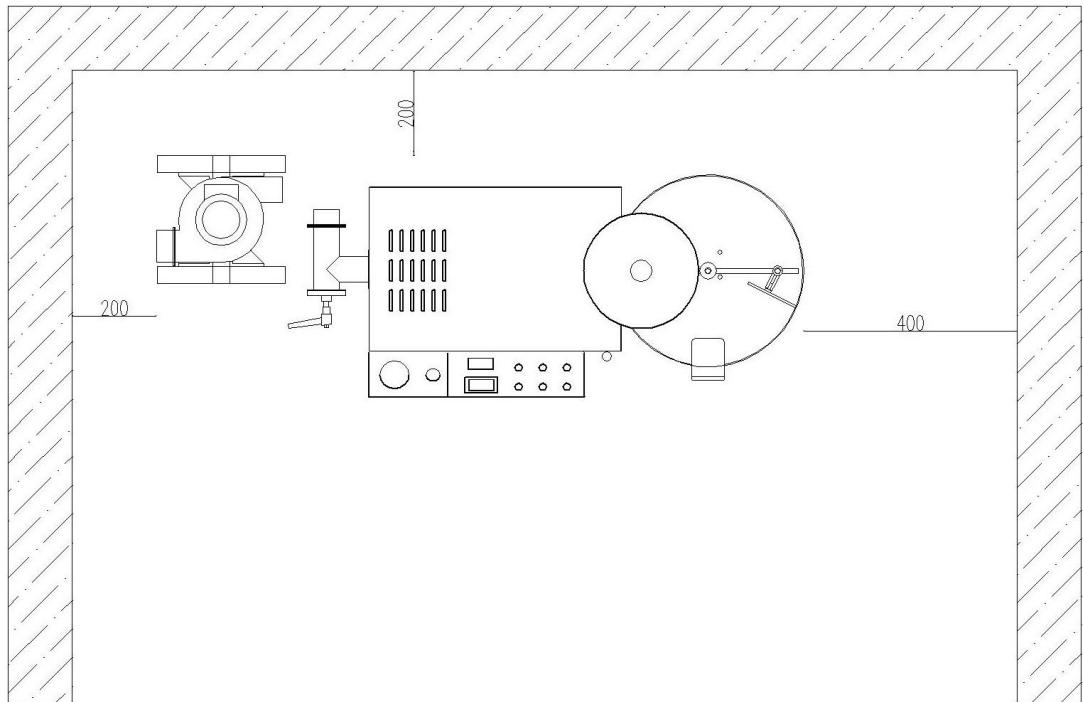

Note the minimum space placed roasting machine, leave enough room for maneuver.

Install a fire extinguisher near the coffee roaster

Installation

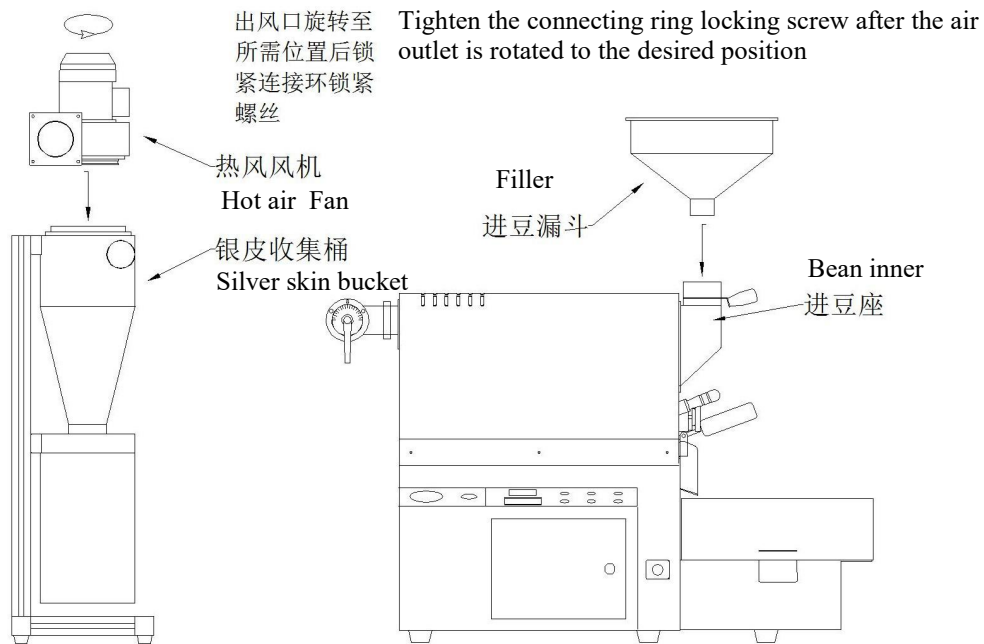

Diagram of roaster installation connection

Roaster installation

- * Connect the bean funnel to the coffee roaster.
- * Connect the hot air fan heel with the silver skin collector.
- * Connect coffee roaster host with silver skin collector.

Hot air fan connection

- * The hot air fan and the silver skin collecting barrel can be fixed with three screws. The air inlet and outlet of the upper fan can be rotated 90°.

Silver skin collection bucket connection

- * A quick clamp and a tetrafluoroethylene gasket are used to connect the hot air blower to the sanitary quick pipe of the baking machine.
- * Exhaust Pipe

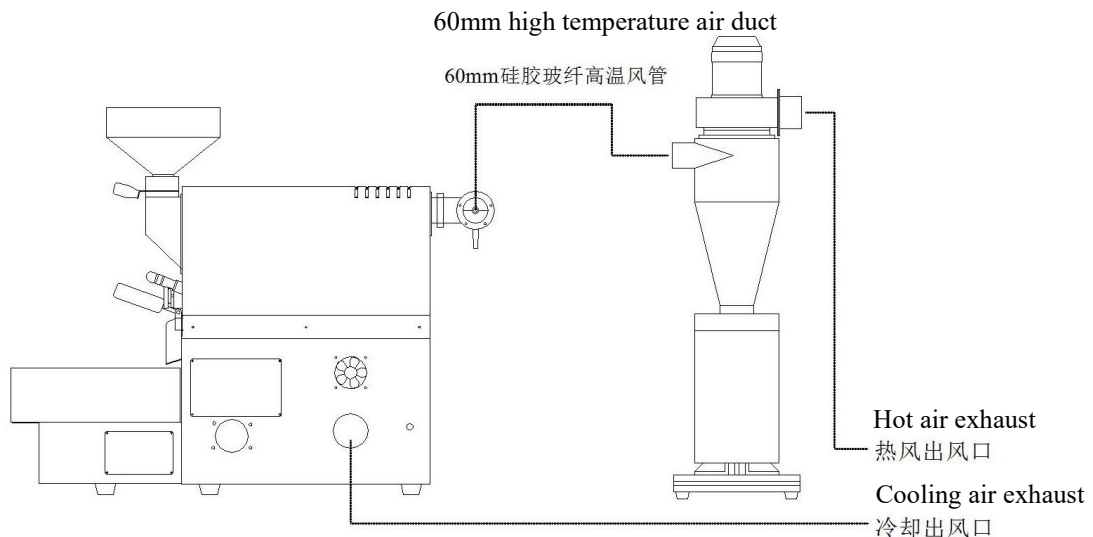

* Hot air pipe connection: metal pipe with diameter of 60mm or high temperature resistant hose is selected, and one end is connected to the outlet of hot air fan of baking machine;The other end should be connected to the air purification system and discharged outside.

* Cooling pipe connection: choose metal pipe with diameter of 80mm or high temperature resistant hose, one end is connected to the cooling vent of the baking machine;The other end should be connected to the air purification system and discharged outside.

Please install air purification system if necessary in accordance with local environmental emission requirements.

Gas line connection

* Connect one end of the gas hose to the gas pressure relief valve;The other end of the gas hose is connected to the gas inlet of the coffee roaster.

* Connect the connected relief valve to the liquefied gas tank.After connecting, make sure the connection is sealed to prevent leakage.

*Gas supply pressure: 4kpa; Air demand: 5m³/h.

Electrical Equipment

* Connect the power cord and the hot air blower coffee roasting machine host, and tighten the locking ring.

Make sure the machine is grounded.

* Plug in the roasting machine.

* Make sure the machine is grounded.

Check the installation

Check and make "✓"

The roasting machine has been placed firmly. ()

- Fixed silver skin collection bucket. ()
- Fixed hot air fan. ()
- Has been fixed into the beans funnel. ()
- Fire appliances are ready. ()
- The appliance is connected. ()
- The exhaust pipe is installed. ()

V.Safety

If the machine in coffee beans temperature exceeds +250 °C, beans spontaneous combustion may occur, resulting in people were injured.

- ▶ Close the heating immediately
- ▶ Remove the beans to cool
- ▶ Sprinkle if necessary

Dark fire

Runtime, silver pail, and silver leather container and fuel in the exhaust pipe may occur spontaneous combustion.

- ▶ coffee beans to ensure there are no impurities.
- ▶ Timely empty silver skin collection bucket

Power-off

In case of power failure, the beans may be due to the spontaneous combustion temperature is too high, causing injury.

- ▶ Open the door beans, baked with a toggle lever tub, coffee beans have been removed
- ▶ In the coffee bean temperature is too high attention to take appropriate measures.

Hot surface

Into the Bean Block, exhaust pipe, silver skin collection bucket, roasting drum and the combustion chamber of the heating surface are likely to cause strict heavy burns.

- ▶ Do not touch the hot surface.
- ▶ should wear protective gloves when working on a hot machine.
- ▶ Do not use flammable materials near the machine.

VI. Ready to produce

Turn on the power

The air switch to "on" position.

Note: After correctly connecting the power, make sure the beans into the bean gates and doors are in a closed state, then the following steps can be performed.

Start-up

Press roaster "Power" switch to start the roasting machine

Start roasting

Press roaster "heating" switch, the machine starts warming

By adjusting the roasting machine "fire" knob to observe the roasting machine power table adjusted to fit the size of the fire.

The roasting machine is preheated before each roasting. The role of preheating is to make the roasting machine into working condition states, adapt the rhythm of roasted coffee, depending on the size and firepower of the throttle opening, warm-up time not always the same.

Preheating stage power control in general about 1-1.5kpa, fully preheated roasting machine.

Depending on the amount of roasting, choose the appropriate preheat temperature.

Usually turning point is about 100 °C. 1-500g beans to 170 °C, 1Kg can be preheated to 200 °C. 2Kg more than you need to be preheated to above 230 °C.

Roasted coffee generally include: roasting stage dewatering stage ----
--1st crack crack ----- 2nd crack -----Cooling the beans. According to these five process your roasted coffee to determine the appropriate timing and degree of roasting.

NOTE: Throughout the process of roasting, be sure to stay next to the roasting machines were observed adjustment is strictly prohibited without permission to avoid the failure of roasting, or even fire!

1. Preheat

After the machine warms up, the beans will be loaded into the bean hopper, then open the gate, beans automatically fall into roasting drum, finally close the intake gate. At the same time press "Start" Artisan on the roasting process begins.

Any raw beans into the roasting compartment moment, the specific heat is the greatest, that requires the most thermal energy for it to heat up, so do not worry early baked beans burns! Pre-heating machine is to allow the beans to heat up as soon as possible, to prepare quickly, do not waste time in the early!

2. Dehydration

At 150-160 °C beans occurred obvious change in color from green color to fried rice, and accompanied by a significant change in odor is about to begin a series of chemical reactions can be sketchy have to understand, Prior to this operation just to prepare for roasting.

There is only a tiny difference between insufficient dehydration and over dehydration, eyes alone are difficult to judge, need nose smell. This point is difficult to explain in words, is probably converted into wheat grass fishy smell, sense more natural drying out

At this point if the moisture content is still high especially hard beans, eventually may be very astringent taste!

Conversely dehydration time long beans no water, and 1st crack will be obvious, not enough rich full taste full. Roasting personnel required number of tests in order to obtain the most perfect beans time.

3. Near 1st crack

The next time, coffee beans requires a lot of energy to prepare for a blast. Water vapor inside the beans

The fiber requires a lot of energy, a lack of crack if before the heating rate is too low is likely to cause a fire Crack obvious (heating rate is generally controlled at about 10 °C per minute)

4. 1st crack

1st crack is an exothermic process, has an obvious link with baked beans specific heat has been declining, this time as

If you want to control 1st crack must transfer a small fire, and some need to be controlled in advance, but do not

How to adjust the tube, do not lose body heat, hypothermia is likely to cause the reaction stalled, resulting in stiff baked beans, which will directly lead to the failure of roasting.

A sporadic crack sounded - intensive - and then sporadically, the process will generally experience 1.5-3 minutes.

Beans less firepower is difficult to hear; longer than 2 minutes, the beans will feel more neat and short.

However, these are not the most important, it is important to control the heating rate of the reaction is reasonable sufficient, avoid cooked this way out of the beans will tastes better.

5. The end of 1st crack – 2nd crack

Next will usher in a period of calm - beans began to heat. With the deepening of roasting, beans

Slowly fold open, the aroma of a significant change, you can choose a lot of beans at this time the beans cool down.

Be careful at this time, not because the thermometer does not move to go plus the fire, do not move the thermometer

The reason is because the beans and heat in order to prepare 2nd crack, wait for a while 2nd crack began.

6. 2nd crack

Two crack once started will quickly heat large, and further transfer of small fire or directly off the fire. This

When the beans have been very light, very small specific heat, roasting phenomenon since the release of thermal energy can make beans has been baked into deep, sampling at any time, and be ready to cool down! Then fast response, a difference of 5 seconds will taste very different.

7. Cooling the beans

Pan before the arrival of the first step to open the point "cooling off" switch, then stirring blade and a cooling fan is turned on.

Only need to open the door out of the beans, cooked beans will automatically fall into the cooling plate rapid cooling, the cooling process is vital, highly exothermic roasting late if not quickly controlled, cooked beans inside will continue roasting, bake deep is likely to cause accidents.

After a few minutes completely cooled cooked beans, you can open the door to cool the beans on the disc automatically under beans, baked roasting the bundle.

Roasting tips: common extent roasting

City -	1st crack in the late (mainly used in measuring cup)
City	Refers to the end of 1st crack around
City +	After 1st crack of about 30-1 seconds (shallow roasting a single product)
Fullcity -	Second crack odor before significant changes, about the end of 1st crack of about 1 and a half minutes (acid of soft beans)
Fullcity	Two crack close to the beginning or the first sound around
Fullcity +	Two explosive start when is not yet dense phase (high altitude hard bean)
Vienna	Generally considered to be critical to the intensive 2nd crack

Roast are all substantially the scope required to meet the taste of smell to comprehensive judgments

Shutdown

- 1.Close "fire" switch.
- 2.Empty the roasting bucket.
- 3.Empty the cooling pan.

4.Wait for the machine to cool down a bean temperature of about 50degrees, turn off the power button

VII.Malfunction

malfunction	the reason	exclude
The roasting phase is too slow	Roasting too much coffee beans in the drum	Add a small amount of coffee in the next batch Beans Increase the firepower to the desired value
	Fire is too low.	Slowly adjust the spin damper adjustment
	Roasting exhaust is too small	Slowly adjust the small throttle adjustment
	Roasting exhaust is too large	Eliminate the blockage
	Roasting gas exhaust fan Or the exhaust pipe is blocked	
	Roasting gas exhaust fan does not operate	Check the power supply Check roasting gas exhaust fan. necessary When replacement
The roasting phase is too fast	The coffee beans in the roasting drum are too small	In the next batch to add more coffee Beans. The gas pressure is reduced to the required number value.
	Gas pressure is too high.	
Coffee beans are inhaled together	Airflow is too strong	Slowly adjust the small throttle adjustment
Roasted coffee beans	The damper is closed	Slowly open the damper adjustment.
In the silver skin	Hot air fan or exhaust	Eliminate the blockage.

content	pipe blocked	
Too high.	The hot air fan is not running	Check the power supply. Check the hot air fan.If necessary replace.
Front bearing appears	Bearing dry	Roasting drum shaftlubrication, bearings. Check the bearings. If necessary, more change.
Grinding noise		
The roller touches the front panel	The gap between the rollers is too small	Adjust the gap of the roasting drum.
Between the drum and the front panel	The gap of the roller is too large	Adjust the gap of the roasting drum.
Spilled coffee particles.		
malfunction	the reason	exclude
The cooling phase is too slow	Punching plate clogging. Cooling fan or exhaust pipe is blocked	Clean the punch plate. Eliminate the blockage.
	The cooling fan is not running	Check the power supply. Check the cooling fan.When necessary Line replacement.
The stirrer is not running	The motor of the stirrer is not running	Check the power supply. Check the motor. If necessary, more change

There are exhaust pipe	Silver skin container is full	Empty the silver skin container.
A large number of silver skin	Silver skin collection plug	Eliminate the blockage
	Silver skin container is not sealed	Check the adjustment position